

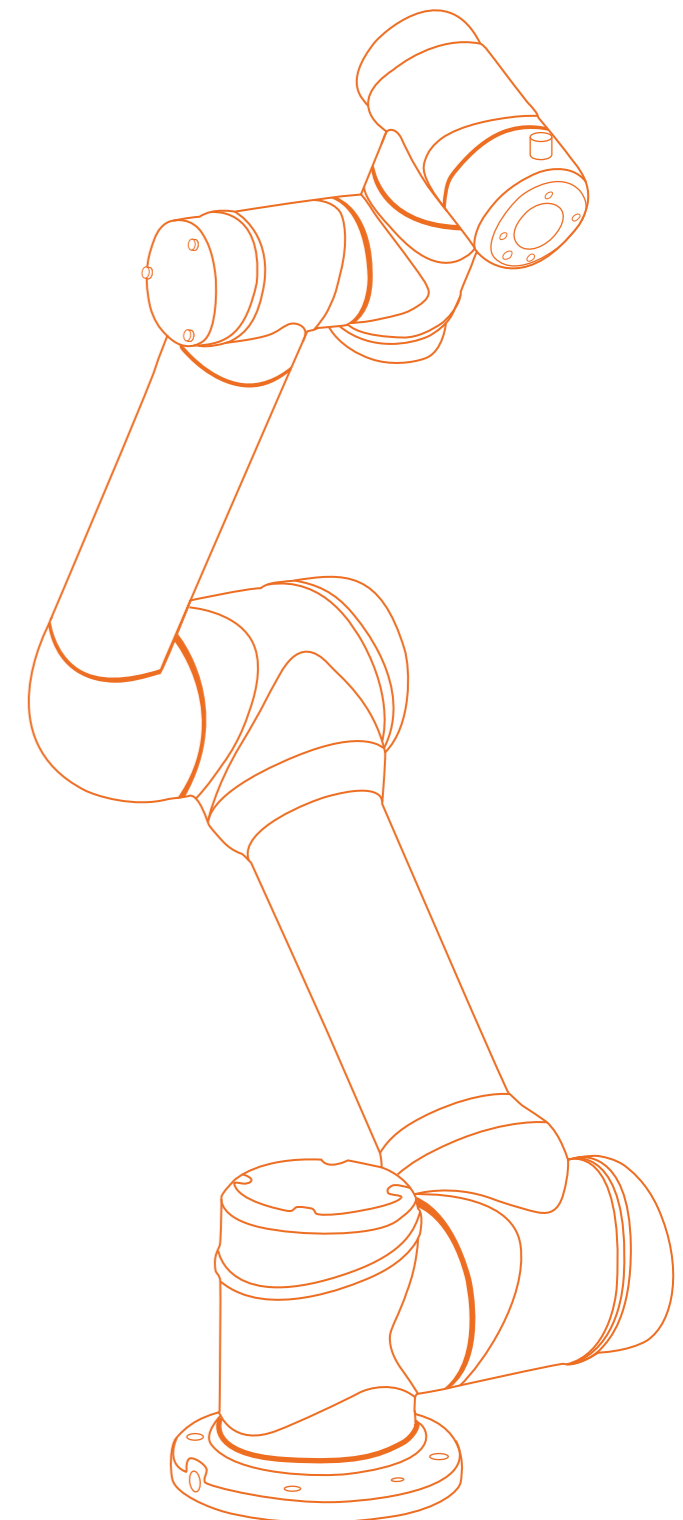

COLLABORATIVE ROBOT

—
SMART INNOVATION
COLLECTIVE FUTURE



© Aubo Robotics EN 202601 Catalog

AUBO (BEIJING) ROBOTICS TECHNOLOGY CO., LTD

Headquarters:

10/F, Haiqing Tower, No.6 West Nongkeyuan Rd., Haidian District, Beijing, China

Production Base:

Block A, Mingseal Technology Building, No. 18 Changwu Middle Road, Wujin District, Changzhou City, Jiangsu Province, China

65 Chengli St, Qidu Town, Linzi District, Zibo City, Shandong Province, China

Tel: +86 10 8859 5859

E-mail: info@aubo-cobot.com

www.aubo-cobot.com

CORPORATE PROFILE

Established in 2015 as a national high-tech enterprise, AUBO Robotics has emerged as China's pioneer in full-stack collaborative robot innovation. With 60% of our workforce dedicated to R&D and 100+ proprietary patents, we have achieved 100% localization of core components, including servo drives, control systems, and force-torque sensors – a technological milestone recognized through certifications spanning EN ISO 13849-1:2015 (PL=d, CAT 3), CE, UL, and SEMI S2 compliance.

Our modular collaborative robots, engineered with intrinsic safety systems and intuitive programming interfaces, drive transformation across 12+ industries. From precision electronics assembly in 3C manufacturing to sterile pharmaceutical packaging, from adaptive welding cells in automotive plants to AI-driven service robots in healthcare, AUBO solutions empower enterprises with deployment-ready automation.

Positioned at the forefront of industrial evolution, we build an open innovation ecosystem through strategic alliances with global partners. By integrating edge computing capabilities with digital twin platforms, AUBO delivers plug-and-play solutions that reduce deployment time by 70% compared to traditional systems.

Headquartered in Beijing with advanced manufacturing bases in Jiangsu and Shandong provinces – including a 20,000m² smart factory with annual capacity exceeding 5,000 units – our vertically integrated operations ensure seamless quality control from component production to system integration.



Recognized Leader in Specialized Manufacturing



Setter and Promoter of Industry Standards



Fully Independent & Full-Stack Proprietary Technology



One-Stop Collaborative Robot Ecosystem

Shaping Intelligent Collaboration Worldwide

THE POWERHOUSE

Wei, Hongxing Chairman

- Member, IEEE (Institute of Electrical and Electronics Engineers)
- Member, ACM (Association for Computing Machinery)
- Committee Member, National Technical Committee on Robotics of Standardization Administration of China
- Head, National Working Group on Robot Modularity Standards of China
- Principal Investigator for multiple projects under 863 Program and NSFC (the National Natural Science Foundation of China)
- Recipient of 5 Provincial and Ministerial-level Awards
- Selected for the Beijing Nova Program (Rising Star in Science & Technology)
- Author of over 100 academic papers, 2 monographs, and 2 textbooks



AUBO Robotics holds nearly 300 authorized patents, including 96 invention patents. A key player in industry regulation, AUBO has led or participated in the drafting of 28 national and industry standards and serves as the Secretariat for the Collaborative Robot Working Group of the National Automation Standardization Committee in China.



DOCTORAL DEGREE

10+



MASTER'S DEGREE

60+



TOTAL WORKFORCE

500+



Global HQ: Beijing, China



Jiangsu Base



Shandong Base

SMART INNOVATION COLLECTIVE FUTURE



TABLE OF CONTENTS

01

AUBO Brand Excellence

Corporate Profile	P01
Milestones & Evolution	P03
Accreditations & Recognitions	P05

02

Research & Development

Innovation Ecosystem	P06
Production Capabilities	P07
Quality Assurance	P08

03

Smart Solutions Portfolio

Our Advantages	P09
i-Series Cobots	P11
iS-Series Cobots	P13
Hybrid Mobile Cobot	P15
Palletizing Workstation	P17
Welding Workstation	P18
Screwdriving Robot	P19
Industry Applications	P23
Success Stories	P24

04

Service and Support

Global Services	P31
Parameters	P33
Dimensional Drawings	P37

MILESTONE

Changzhou factory commenced operations.

Recognized as a National High-Tech Enterprise in China.

Initiated mass production of AUBO-i5.

2016

MASS PRODUCTION START

Became China's first cobot manufacturer to achieve EN ISO 13849-1:2015 certification (PL=d, CAT3).

Designated as a High-End Equipment Standardization Pilot Enterprise in China.

2018

REDEFINING INDUSTRIAL SAFETY BENCHMARKS

Commissioned the world's first cobot-powered smart factory.

AUBO C-series cobots launched.

Recipient of the prestigious First Prize for Science and Technology Progress in China's machinery industry.

2020

AUBO MASSAGE ROBOT DEBUT

Launch of AUBO mobile manipulators and AUBO-i20 cobot.

Established Robotics Lab for Health System Engineering in China.

Recognized as a National Manufacturing Single Champion in China.

2022

AUBO MOBILE MANIPULATORS DEBUT

Launch of the AUBO-iS35 cobot and AUBO screwdriving robot.

Sales milestone: over 30,000 units sold.

Launched a global Robot Trade-in Program.

2024

SALES MILESTONE: OVER 30,000 UNITS SOLD

2015

COMPANY FOUNDATION

Establishment of AUBO Robotics.

Strategically established operational hubs in the US and Germany, complemented by domestic centers in Shenzhen and Shanghai.

The world premiere of the AUBO-i5 cobot.

2017

GOING GLOBAL

Academician Ni Guangnan was appointed as chief scientific advisor.

Launched next-gen cobots including AUBO-i3/i7/i10.

The product line achieved tri-market compliance (CE/UL/KCs).

2019

NATIONAL STRATEGIC TECHNOLOGY PARTNER

Appointed lead implementer of two National Key R&D Program intelligent robotics projects.

Established and chaired the National Collaborative Robotics Standardization Working Group.

AUBO i16 industrial-grade cobot debuted globally.

2021

SALES MILESTONE: OVER 10,000 UNITS SOLD

Zibo factory commenced operations. Achieved SEMI S2 & cleanroom class 5 certification cluster.

Founded the Cobot Journal, the first SCI-indexed periodical dedicated to cobot research.

Designated as the National Little Giant Enterprise in China.

2023

INTRODUCTION OF ARCS ROBOT OS

Sales milestone: over 20,000 units sold.

Launch of iS, iH, C (new version), and S-series cobots.

Introduction of ARCS Robot OS.

AUBO S-series sweeps 5 major global awards.

2025

12,000 Units Annual Delivery Volume

First Prize, Machinery Industry Science and Technology Award
Beijing Quality Management Nomination Award

11 New Projects Major Special Projects Undertaken

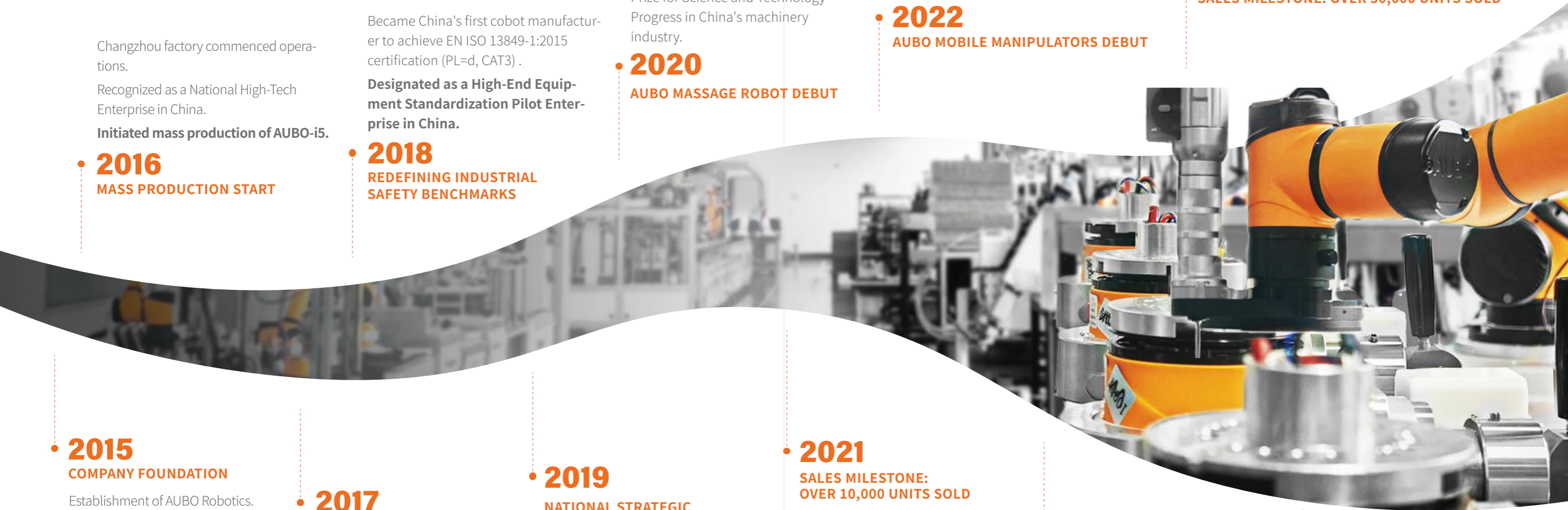

281

Valid Granted Patent

97

Granted Invention Patent

162

Granted Utility Model Patent

80

Registered Software Copyright

22

Granted Design Patent

ACCREDITATIONS & RECOGNITIONS

As a trailblazer in collaborative robotics, AUBO is driven by a singular focus on market demands and relentless innovation. By transforming cutting-edge research into real-world solutions, we have earned industry-wide recognition and multiple distinguished honors.

Industry Leadership & Honors

- **Manufacturing Champion: National Single Champion Demonstration Enterprise.**
- **Elite Enterprise: National High-tech & "Little Giant" Enterprise.**
- **Sales Leader: No.1 Domestic Sales Volume (2017-2019, 2021-2022).**
- **Global Potential: IEEE Most Promising Cobot Company.**
- **Top Tech Award: First Prize, Machinery Industry Sci-Tech Award.**

Standardization Authority

- **Pilot Unit: National High-end Equipment Standardization Pilot.**
- **Standard Setter: Drafter of National Cobot Standard (GB/T 36008-2018).**
- **Secretariat: National Automation Standardization Committee (Cobot Working Group).**
- **Global Expert: Member of ISO-TC299/WG10 (Robot Modularity).**

*Data source: from MIR

PRODUCT ASSURANCE

AUBO Robotics is dedicated to providing customers with safe and reliable collaborative robots. Our products have achieved comprehensive global certifications, including **EN ISO 13849-1:2015 (PL=d, CAT 3)**, **CE (EU)**, **NRTL (North America)**, **KCs (Korea)**, **CR (China)**, **SEMI S2**, and **ISO Class 5 Cleanroom** standards. These certifications guarantee safety and reliability throughout the product's entire lifecycle.



Industry-first PL=d, CAT 3 safety certification in China.



ISO 13849-1:2015

ISO/TS 15066:2016

欧盟CE

北美NRTL

Defining the Standards for Chinese Cobots

Backed by superior R&D capabilities and industry leadership, AUBO has contributed to drafting 28 robot standards (leading 3 national standards) and undertaken 21 key national projects (leading 10).

National Standards Led by AUBO

GB/T 39402-2020: Design Specifications for Industrial Robots Oriented to Human-Robot Collaboration

GB/T 38560-2020: General Drive Module Interfaces for Industrial Robots

GB/T 43199-2023: Testing Specifications for Robot Multi-dimensional Force/Torque Sensors

Key National Projects (Selected Cases) Led by AUBO

R&D and Integration Verification of Integrated Joints for Collaborative Robots

Application Demonstration of Collaborative Robot Systems for Assembly of Typical Automotive Components

Mobile Manipulator Project

3 Led Formulation of 3 National Standards

28 Contributed to 28 National & Industry Standards

10 Led 10 National Flagship Program

21 Contributed to 21 National Key R&D Programs



SERIES COLLABORATIVE ROBOT

The AUBO i-series cobots feature a payload capacity ranging from 3kg to 20kg. Compatible with a wide variety of end-effectors, they deliver consistent performance in terms of precision, speed, and stability. Designed to handle diverse applications across various industries, the i-series is built to better meet customer and market demands.



Product Advantages

- 01 High Accuracy** Utilizes self-developed high-precision encoders to further improve repeatability and power-on positioning accuracy, resulting in more stable operational trajectories.
- 02 High Speed** The all-new upgraded model increases working speed by 10%-20% over the previous generation. The 6-DOF robotic arm ensures efficient operation and maximizes work efficiency.
- 03 Versatile Functionality** Integrated with RS485 interface and end-effector drag-to-teach function at the flange. Supports high-current power supply and establishes direct communication with diverse peripherals, offering greater flexibility and convenience.
- 04 Optimal Safety** Certified by multiple industry safety standards for stability and reliability. Features high-sensitivity collision detection to maximize safety during Human-Robot Collaboration.



Application Fields

3C, automobile, hardware and household appliances, sanitary appliances for kitchens and bathrooms, medical health, scientific research and education, catering, new retail, chemical products for daily use, and logistics.

AUBO-i3

Payload: 3kg
Weight: 16kg
Repeatability: ±0.02mm
Reach: 625mm

AUBO-i5/i7

Payload: 5kg/7kg
Weight: 23.3kg/24.4kg
Repeatability: ±0.02mm
Reach: 886.5mm/786.5mm

AUBO-i10/i12

Payload: 10kg/12kg
Weight: 39.2kg/40.6kg
Repeatability: ±0.03mm
Reach: 1350mm/1250mm

AUBO-i16

Payload: 16kg
Weight: 38.9kg
Repeatability: ±0.03mm
Reach: 967.5mm

AUBO-i20

Payload: 20kg
Weight: 63.7kg
Repeatability: ±0.05mm
Reach: 1650mm

iS SERIES COLLABORATIVE ROBOT

With a comprehensive portfolio covering payloads from 3kg to 35kg, the AUBO iS series high-performance cobots meet diverse industry needs. It is especially optimized for precision manufacturing, spraying, and harsh environments, ensuring superior safety and ease of use.



Product Advantages

- 01 Enhanced Performance** Delivers high precision and speed with repeatability between $\pm 0.02\text{mm}$ and 0.05mm . It supports a payload range of 3-35kg—including the pioneering 35kg model—and achieves tool speeds up to 4.2m/s.
- 02 All-New Design** Features an optimized design with a payload-to-weight ratio up to 1:3.2, powered by advanced control algorithms. The rugged, fully enclosed architecture offers protection ratings up to IP68.
- 03 Compact & Agile** System usability is upgraded with a lightweight 1kg Teach Pendant (wireless optional) and a compact control box. A multi-functional tool flange comes standard, allowing for built-in 6-DOF force/torque sensors.
- 04 Extensive Applications** The platform supports specialized variants to meet specific industry demands, including Force Control, Medical, Explosion-proof, Welding, Palletizing, and Integrated Vision versions.



Application Fields

The iS series cobots are widely applicable across various industry scenarios and are particularly suitable for precision manufacturing, painting, and special circumstances such as harsh, sensitive environments.

AUBO-iS3	AUBO-iS7	AUBO-iS10	AUBO-iS20/iS20L	AUBO-iS25	AUBO-iS35
Payload: 3kg	Payload: 7kg	Payload: 12kg	Payload: 20kg/20kg	Payload: 25kg	Payload: 35kg
Weight: 16kg	Weight: 21.5kg	Weight: 36kg	Weight: 64kg/72kg	Weight: 75.6kg	Weight: 172kg
Repeatability: $\pm 0.02\text{mm}$	Repeatability: $\pm 0.02\text{mm}$	Repeatability: $\pm 0.03\text{mm}$	Repeatability: $\pm 0.05\text{mm}/\pm 0.05\text{mm}$	Repeatability: $\pm 0.05\text{mm}$	Repeatability: $\pm 0.05\text{mm}$
Reach: 625mm	Reach: 886.5mm	Reach: 1300mm	Reach: 1647mm/2000mm	Reach: 1700mm	Reach: 2100mm

S SERIES COLLABORATIVE ROBOT

Designed specifically for the commercial and service sectors, the AUBO S series features an ultra-lightweight and compact design. Available in 2kg and 5kg payload options, it offers rich expansion interfaces and multiple intuitive interaction modes, fully supporting the ARCS wireless teaching function.

Product Advantages

- 01 A Grand Slam Winner** Red Dot: Best of the Best, IDEA Gold, G-Mark, CGD Gold (2023), and iF Design Award (2024).
- 02 The Fusion of Art & Function** Featuring next-generation industrial design, the robot combines a sleek, minimalist aesthetic with a futuristic color palette, which perfectly fits for customer-facing commercial environments, elevating the premium quality of any integrated solution.
- 03 Ultra-Compact & Agile** Powered by proprietary deep miniaturization technology, the robot is exceptionally lightweight and agile, with a body weight of just 13.5kg. The control box has been optimized to an ultra-compact 1L volume, seamlessly adapting to diverse and demanding integration requirements.
- 04 Rich Interfaces & Powerful Functionality** Minimalist in form, yet maximalist in capability. The control box is equipped with a comprehensive suite of interfaces, including Safety I/O, Configurable I/O, Analog I/O, Industrial Ethernet, and RS485. The tool flange supports RS485 and I/O communication, alongside support for mobile wireless teaching.

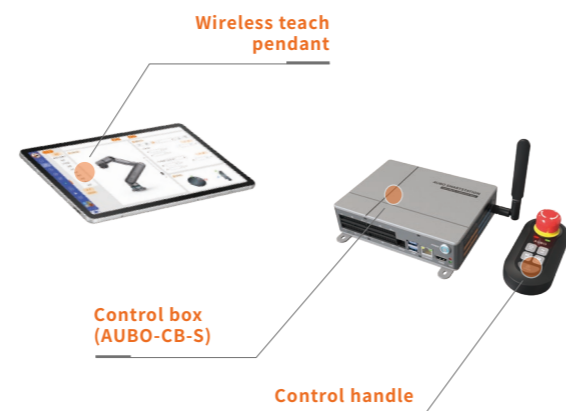

C SERIES COLLABORATIVE ROBOT

Developed specifically for the service and new retail sectors, the AUBO-C Series is available in 3kg and 5kg payload options. Tailored to meet the unique demands of these industries, it offers an exceptional price-performance ratio and a rapid ROI.

Product Advantages

- 01 Lightweight, Flexible & Easy to Deploy** Supports rapid deployment with flexible mounting options. It is easy to integrate and offers an exceptional price-performance ratio.
- 02 Rich Interfaces for Easy Integration** The highly integrated control box features diverse interfaces. The tool flange supports General I/O, Analog I/O, and configurable power outputs (0/12/24V).
- 03 Optimized for Commercial Performance** With a 3-5kg payload capacity and $\pm 0.1\text{mm}$ repeatability, it perfectly meets the performance requirements for integrated products in commercial scenarios.
- 04 Rapid Customization** Hardware supports customization of colors and logos, as well as deep OEM collaboration. The software provides multi-level open interfaces, enabling secondary development or project-specific customization based on user needs.

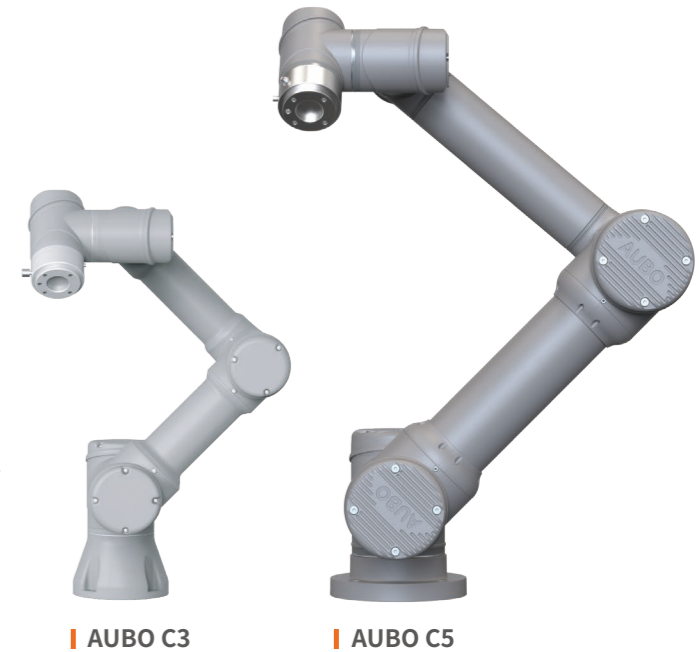

Application Fields

Suitable for application scenarios in new retail and the service sector.



Global Design Awards



AUBO MOBILE MANIPULATOR

AUBO-AMR300S

AUBO Mobile Manipulator offers flexible control over the robotic arm, mobile base, vision systems, and end-effectors. The all-in-one control system delivers an interactive experience that is simple, safe, reliable, and highly scalable, ensuring efficient collaboration across all scenarios.

Designed to adapt flexibly to diverse work environments, the system streamlines complex operations. By achieving perfect coordination between the arm, vision, and mobility, it can effortlessly execute a wide range of complex tasks.

Product Advantages

- 01 All-in-One Integration** The system features a unified control architecture that flexibly manages the cobot, mobile base, and vision systems, delivering a seamless "one-click" collaborative experience.
- 02 Seamless Information Flow** Users can access real-time status updates across all devices with zero latency.
- 03 Flexible Expansion** The platform supports flexible configurations with 5-25kg payload cobots, various mobile bases, 2D/3D vision systems, and end-of-arm tooling.
- 04 User-Friendly Operation** Programming for the cobot, mobile base, and vision is integrated into a single software platform using flowchart-based programming. With user-editable task modules, users can easily design robot behaviors and utilize vision guidance for high-precision positioning.
- 05 Safe Navigation & Control** Equipped with high-precision SLAM LiDAR for navigation and positioning, and differential drive control for smoother movement. The system features laser-assisted safety with auto-deceleration upon personnel detection and active obstacle avoidance.
- 06 Collaborative Synergy** Powered by AUBO robot operating system, the platform enables coordinated control of the cobot, mobile base, and vision systems. It supports both standalone operation and multi-robot fleet scheduling solutions.



Application Fields

Suitable for semiconductor industry, 3C electronics & precision manufacturing, healthcare, power & energy inspection, intralogistics & warehousing.

AUBO PALLETIZING WORKSTATION

It introduces the AUBO Palletizing Workstation, a user-friendly solution that revolutionizes palletizing. With its intelligent design and adaptability, it offers a personalized user experience. This versatile solution is efficient and easy to operate, making it a valuable addition to any palletizing scenario.

Product Advantages

- 01 Simplification and Easy Operation** The palletizing workstation features a one-push start function, allowing for easy generation of pallet patterns with a simple operation. It's easy to use, even for beginners.
- 02 Comprehensive Monitoring, Safe and Reliable** It is equipped with safety vision monitoring and safety IO interfaces and possesses a collision stop function. With 360-degree comprehensive detection, it ensures the personal safety of operators and is stable and reliable.
- 03 Controllable Solutions, Flexible Deployment** The independently developed palletizing workstation by AUBO Robotics is a highly integrated product. It can be professionally customized according to different industry characteristics, ensuring the overall solution is controllable. Deployment can be completed in 2 hours, saving operational costs and offering high cost-efficiency.
- 04 Flexible Production, Widely Applicable** Taking into account the diversity of palletizing methods across industries, the palletizing workstation supports various types of pallet patterns, including overlapping and alternating styles. With a maximum height of 2.5 meters, it meets the diverse palletizing needs of different industries.
- 05 Palletizing Process Package, Extremely Intelligent and User-Friendly** Each AUBO palletizing workstation comes standard with a palletizing process package. This includes both software and hardware cooperation, with strong inclusiveness. The process package is compatible with all models of AUBO collaborative robots, significantly increasing palletizing efficiency."

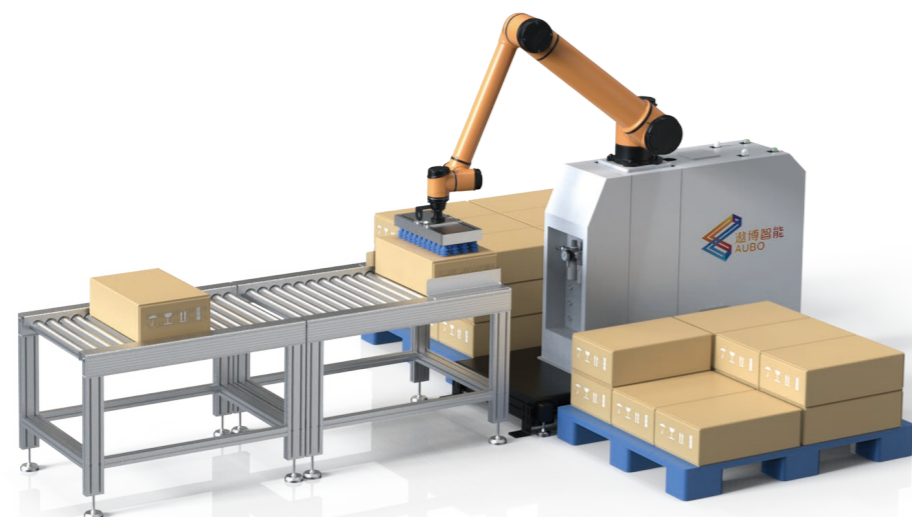

www.aubo-cobot.com

AUBO WELDING WORKSTATION



Product Advantages

- 01 Simple layout, flexible movement** Unlike traditional welding robots, the AUBO welding workstation is compact and easy to move. It can be combined with a magnetic base, gantry, truss, etc. Suitable for quick switching in welding scenes with small batches and a variety of products, deployment can be completed in 10-15 minutes.
- 02 Easy-to-use welding software** Combining welding technology and practical experience, the parameters are simplified, and the settings are digitalized. Ordinary workers can also complete welding tasks with different trajectories, materials, and process requirements through the parameter setting interface, meeting most welding scenarios.
- 03 Low cost, high return on investment** The core components are made in China, with an average investment payback period of 6-12 months.
- 04 Equipped with a 6D mouse, efficient and smooth dragging** Equipped with a self-developed 6D mouse with a patented design, it is easy to operate and highly controllable, greatly improving the precision of the collaborative robot's drag teaching; an integrated vision function is optional, with an integrated design, realizing drag-free vision-guided teaching.
- 05 Safety and stability are guaranteed** Supports Level 10 collision detection and sensor safety checks, ensuring the end doesn't drop when powered off, making the product safe and stable.
- 06 High precision** Millisecond-level system response speed ensures positioning accuracy, with a repeat positioning accuracy of up to $\pm 0.1\text{mm}$.

THERAPY ROBOT

AUBO screwdriving robot can be easily deployed onto various machines, eliminating the necessity for external electric screwdrivers and significantly simplifying the screwdriving integration process. The programming process is made straightforward for all users including those with limited technical expertise in industrial screwdriving. AUBO screwdriving robot offers an intuitive user interface and customized project templates specifically designed for screwdriving applications; allowing for quick and easy set up of the robot for the job. AUBO's innovative screwdriving robot brings in a reliable, maintenance-free and cost-effective solution for our clients who want to improve their productivity with more automation.

Product Advantages

- 01 Six-Axis Robotic Arm** Replicates the dexterous and flexible techniques of professional therapists with high fidelity.
- 02 3D Vision + Force Feedback** Achieves millimeter-level positioning and intelligently adjusts treatment intensity based on real-time feedback.
- 03 AI Real-time Path Planning** Dynamically optimizes therapy trajectories to precisely target sore spots and myofascial trigger points.
- 04 Continuous High-Efficiency Operation** Reduces labor costs and significantly boosts operational efficiency, empowering health through technology.

From sports rehabilitation to chronic condition management, AUBO redefines the modern physiotherapy experience with clinical-grade precision and intelligent interaction.

Application Fields

Ideal for a wide range of scenarios, including hospitals, rehabilitation and physiotherapy departments, physiotherapy clinics, moxibustion centers, beauty spas, and high-end leisure clubs.

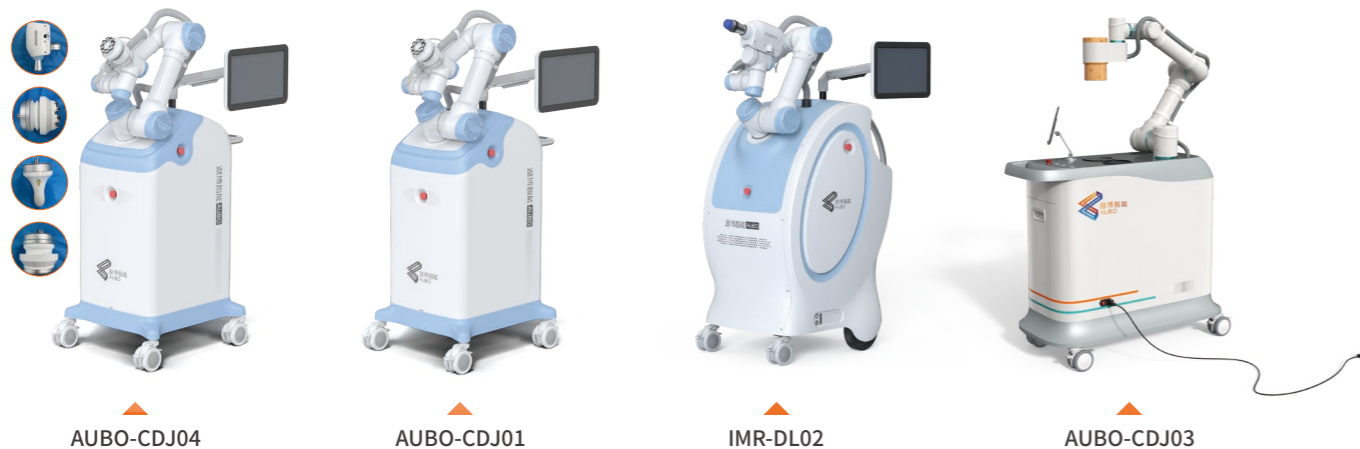

DUAL-ARM COFFEE ROBOT

The Dual-Arm Coffee Robot is a new retail industry application launched by AUBO Robotics. It completes latte art coffee production through a dual - arm collaborative mode, and uses a robotic arm learning system to perfectly replicate master - level flexible latte art techniques, ensuring each cup of coffee delivers both aromatic flavor and visual pleasure.

Product Advantages

- 01 Stable Quality & Cost Reduction** It can continuously produce 300 cups of high - quality latte art coffee daily. For the same output volume, human baristas would need to work non - stop for 15 hours a day, yet still can't guarantee consistent high - quality output for every cup.
- 02 Cutting-Edge Technology** Equipped with an industry - leading dual - arm latte art learning system, it integrates seamlessly with AUBO's open - control platform for collaborative robots. It also supports pattern expansion and online upgrades, while its overall design boasts a strong sense of technological sophistication.
- 03 Intelligent Operation & Maintenance** It enables real - time equipment status monitoring, one - click fault recovery, real - time material inventory display, and material shortage alarms. Remote operation management is also supported. With an easy - to - use ordering system, coffee production can start in just 3 steps, and a master - quality cup of coffee can be ready in 90 seconds.

Application Fields

Suitable for scenarios including hotels, scenic spots, business districts, amusement parks, sports venues, office buildings, and leisure clubs.



APPLICATION CASES



Industrial Field



Non-Industrial Field



3D Scanning and inspection



Engine Screwdriving



mobile phone camera detection



Appearance inspection of auto parts



Coffee robot



Therapy robot

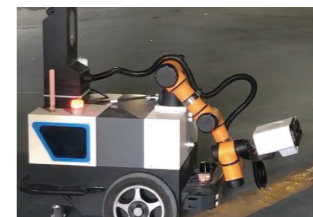

Remote Inspection Robot



Robot with digital twin technology



Inspection of circuit boards



Instrument assembly

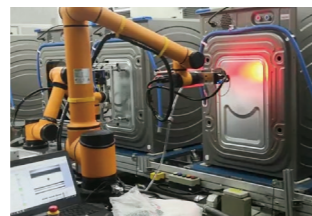

Assembly and screwing of white household appliances



Rubber assembly of auto electronic control systems



Robotic Blind Box Picking



Surgical Robot



Robotic Archive Management



Robotic Assembly Line



Intelligent assembly of auto parts



Welding



Gluing of vehicle windows



Palletizing



Robotic Beverage Station



Medical Inspection Robot



Fault Clearance Robot



Education & Training Platform

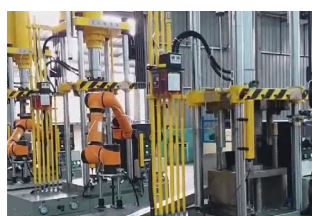

Vacuum cup stretching line



Frame coating



Machine Tending



Machine Tending



Fruit picking



Robotic High-voltage Switchgear Operation



Cleaning Robot



Follow us for more case studies

AUBO ECOSYSTEM

Anchored by our core cobot technology and bridged by a rich product ecosystem, AUBO provides seamless, plug-and-play one-stop solutions. By constructing a robust innovation network and collaborating across the entire supply chain, we are empowering partners to accelerate the growth of the collaborative robotics industry.



AUBO ECOSYSTEM PARTNERS

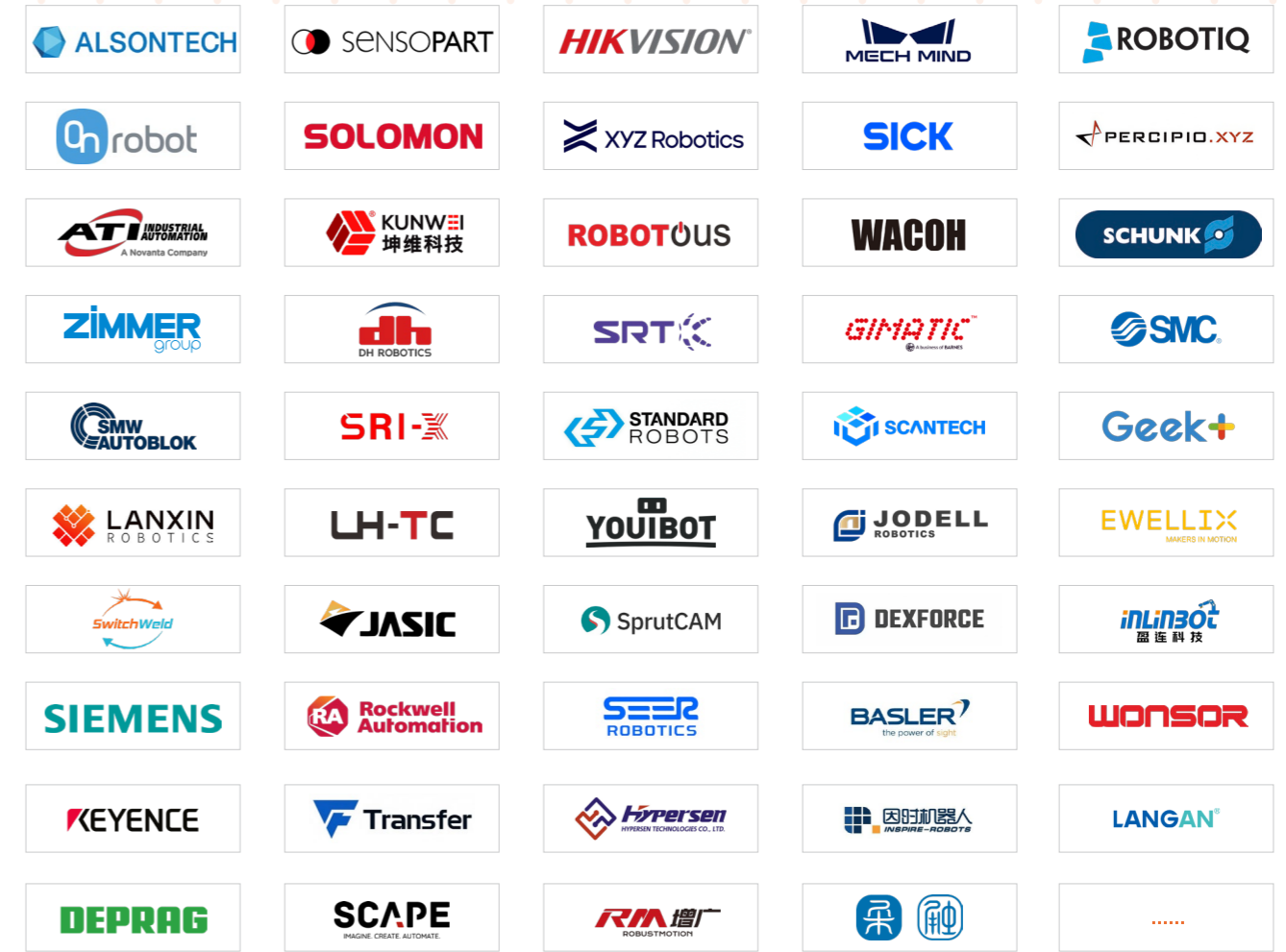

(排名不分先后)

Grow Your Business with the AUBO Ecosystem

Whether you are a system integrator, distributor, or technology consultant, we invite you to help us shape the future of collaborative automation. By joining the AUBO partner network, you gain more than just a supplier—you gain a strategic ally. We empower our partners with a comprehensive support framework, including qualified lead distribution, advanced technical training, and co-marketing resources. Let's combine your expertise with our technology to unlock new markets and achieve shared success.

SUCCESS STORIES

Automobile

Glass Gluing & Sealing

This is the window glass gluing & sealing project customized for a well-known automobile company. Industrial robots or manual gluing is adopted on the traditional production lines. Due to safety restrictions, traditional industrial robots need to be separated from workers by guardrails, and the utilization rate of the production line is limited. It is difficult for manual gluing to control the accuracy and quality.

Quick deployment and small footprint with human-machine collaboration. Uniform gluing speed and glue type control precision of $\pm 0.5\text{mm}$.

Continuous Efficient Operation

Since being put into use in August 2019, the cobot has been running efficiently in good condition for 16 hours a day, and can completely replace manual labor.

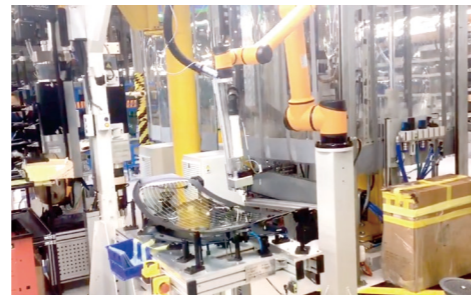

Automobile

Engine Screwing

This is the engine assembly line renovation project of a well-known automobile company. Previously, the screw locking operation was mainly completed by manual labor. Manual operation is labor-intensive, assembly quality is not consistent enough, and it is difficult to improve the yield of finished products. The workshop space is relatively narrow, and the volume and freedom are highly limited. In addition, the screwing has a fixed sequence, the screws are divided into 5 categories and more than 100 sub-models, requiring visual identification of common features. Precise screw torque and high positioning repeatability are required.

The terminal screwing device adopts a screw gun with controllable torque, and it has compact structure and high torque control accuracy. The “eye-to-hand” vision system is selected, and the vision sensor is independently fixed on the bracket to ensure high positioning repeatability.

Reduced Manpower and Increased Productivity

Since operation in April 2019, the production efficiency has been increased by 18%, the product yield has been increased by 12%, the number of personnel has been reduced by 50%, and the labor cost has been reduced by 30%.



3C

Mobile Phone Camera Testing

This is the camera function testing process of a well-known mobile phone manufacturer. Previously, the testing operation was performed by manual labor. The testing environment is divided into indoor and outdoor, and a variety of products, statuses and angles are involved, which are difficult to control for manual labor. The testing is cumbersome and labor-intensive, needs long continuous operation time.

AUBO adopts the mobile cobot solution (AGV + collaborative robot) to work in the live-action studio according to the specified shooting angles.

Stable and Efficient

24-hour operation is possible, and more comparative data can be captured in the same time period, so the efficiency is significantly improved.



Machining

Machine Tending

This is the machining production line renovation project of a well-known company. The company mainly produces precision machinery parts, such as various industrial sewing machine parts, power tool parts and auto parts. With the growth of business volume, manual operation can no longer meet the production demands.

There are a wide range of products, and one person can only handle 2 machines for original production equipment, cannot accurately complete all tasks. Problems such as on-site environment and equipment noise have led to a series of common problems in traditional manufacturing industry, such as labor shortage and increasing labor cost.

Flexible Deployment

The reach of the collaborative robot used in this solution can be up to 1350mm, and the customer can directly deploy on the original factory without changing the layout of the production line. Flexible pick & place of parts is achieved in the narrow working space, and one robot is working for 2 machines. In the original production process, one person can operate up to 2 machines at the same time. After the deployment of collaborative robots, two persons can handle 12 machines at the same time. In this way, the production scale has tripled, while the personnel have not undergone major changes.



SUCCESS STORIES

Healthcare

Massage Robot

Traditional Chinese Medical Massage has always been one of the first choices for people to carry out cervical and lumbar care or pain management. But the shortage of professional massagist has been a major problem in the industry. AUBO developed the massage therapy robot together with our partner, committed to proving safe, temperature-controlled, efficient and standard services in the full process of massage.

The end of the cobot is equipped with a force sensor, a 3D vision, a massage head and a thermal imaging, when the robot arm walks the massage track on the human body, it can ensure the safe and stable operation of the robot without hurting the human body accidentally. And there are different types of strengths that can be switched automatically during the massage according to customers' force preference.



New-retail

Dual-Arm Hamburger Robot

In smart catering industry, AUBO has started business operation officially by cooperating with many restaurants at present. In addition to hamburger robots, the application of robots in restaurants includes stir-fry robots, soup rice robots, drinks robots, frying robots, dessert robots and meals-delivery robots, etc.

In this case, two sets of AUBO i3 cobots are installed inversely, which can be compatible with two collaborative robots to make hamburgers at the same time. After a customer places an order by scanning the QR code, the upper computer sends a signal to the cobots to start the making of hamburger. One cobot mainly grabs bread pieces from the material silo and sends them to the heating furnace, and cooperates with the sauce machine to pour the sauce onto the heated bread pieces; the other cobot takes vegetables and returns the tray. Then, the cobots complete the combination of the upper and lower pieces of bread. After packing, the cobot places the packed hamburger onto the conveyor belt. The customer can scan the QR code to open the pickup window. Here, the purchase process is completed.

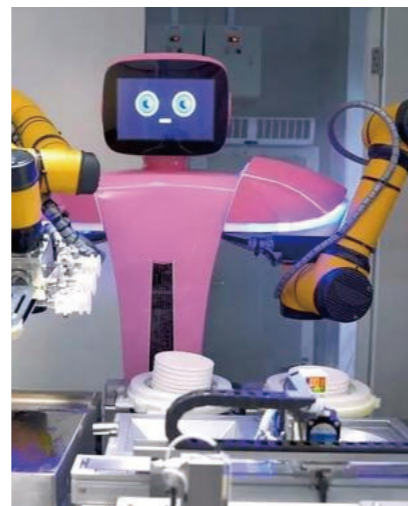

Mobile Cobot

Semiconductor Handling

This is the logistics automation renovation project in the packaging and testing workshop of a semiconductor industry. At present, the industry is mainly based on manual labor. Manual handling has problems such as large vibration, being easy to cause particle pollution, discontinuous operation, wrong handling and poor consistency. The workshop has a high level of cleanliness, a complex layout, a narrow space and a wide variety of equipment with discrete production processes and complex technological processes. The industry order demands are flexible, and it is impossible to form a simple and effective flow-line production.

The mobile cobot and the intelligent dispatching logistics control system help the factory realize an intelligent unmanned production workshop. The mobile cobot is based on the hybrid positioning and natural navigation technology of the laser natural navigation. The indoor positioning repeatability of $\pm 5\text{mm}$ can be achieved without environment modification while the dust-free operation meets the standard. Equipped with a 360°-scanning dual safety lidar, obstacles can be identified intelligently and avoided actively, ensuring safe, high-speed and smooth operation. Target positions such as cartridge holder and tray can be positioned and captured accurately through AI algorithm, 3D visual positioning, force sensor and collaborative robot.



24-hour Operation and Labor Liberation

The solution realizes the die bond among various processes, and 24-hour continuous operation is possible so as to liberate labor, solve information flow conversion, and realize workshop production visualization and production process operation control.

Electric Power Industry

Distribution Room Inspection

This is the automatic distribution room inspection project of a power industry user. At present, the industry is mainly based on manual inspection. The automation equipment in the distribution room operates all the year round, so the failure rate is high. The inspection frequency is high, the work is cumbersome, and the manual inspection burden is heavy. The switch on the low-voltage side of the distribution room cannot be remotely controlled, and automation cannot be achieved through the equipment in the cabinet.

In cooperation with China Unicom, a dedicated 5G channel ensures safe and stable operation of the robots. The big data image recognition intelligently distinguishes equipment fault signals, and provides intelligent safety monitoring for the robot manipulation equipment to prevent misoperation and faults. The inspection robot can independently complete more than ten functions such as equipment inspection, device panel control, faulty part replacement, device restart, and switch opening & closing. The historical alarm records in the device can be viewed to make up for the shortcomings of the inability to collect alarm information when the equipment in the station malfunctions.

Unmanned Operation

The inspection robot has the characteristics of low cost, high reliability, high safety and strong universality, and can be maturely applied to most scenarios in which unmanned equipment operation is required, such as distribution rooms, computer rooms and industrial enterprises.



GLOBAL SERVICES

Around the global headquarters and manufacturing bases, AUBO has established sales centers in the eastern region, southern region and northern region, etc. of China, and overseas after-sales service centers in the USA and Germany, etc. Now, AUBO has more than 200 distributor partners from more than 50 countries in the world, and can provide efficient and convenient professional services for you.

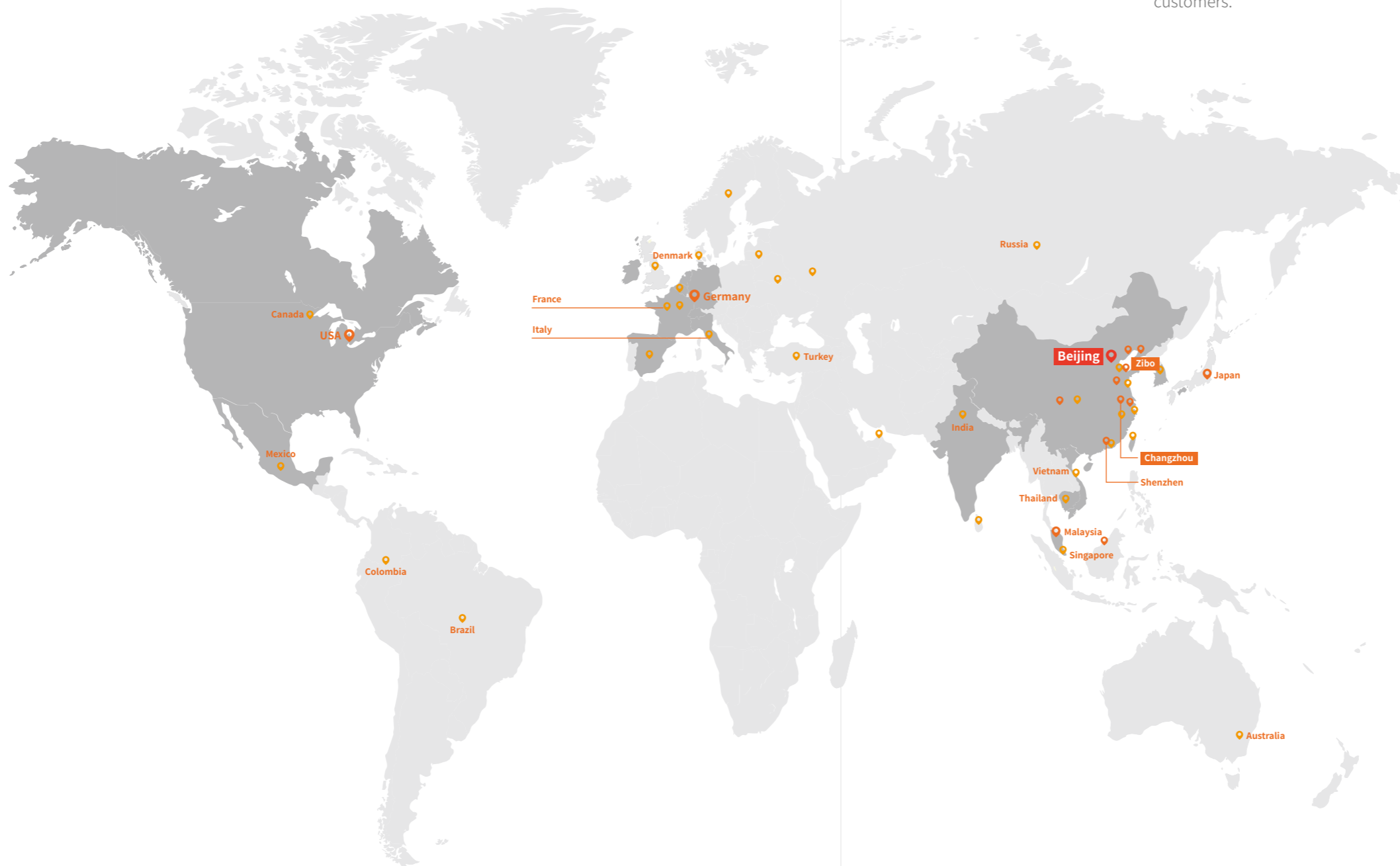

www.aubo-cobot.com

Integrated Services

To provide technology evaluation, accessory selection and debugging services.

Training Services

To provide product usage trainings to distributors free of charge regularly, and cultivate professional robot engineers for customers.

Communication Platforms

To realize real-time technology answers and resource sharing by technical forum and hotline.

Maintenance

To provide lifetime repair and customized maintenance of robots, and provide software upgrading package to customers and instruct them how to install.

★ Beijing

Global Headquarters
R&D Center

● Manufacturing Bases

Changzhou Base
Zibo Base

● Subsidiaries

USA
Japan
Shanghai
Zhongshan

● Offices

Malaysia
Taiwan
Shenzhen
Guangzhou
Tianjin
Changchun
Dalian
Baoding
Xi'an
Qingdao
Suzhou
Jinan
Wuhan
Chengdu
Chongqing
Hengyang
Ningde

Model(i-Series Specification)	i3	i5	i7	i10	i12	i16	i20
Robot Arm Degrees of Freedom	6	6	6	6	6	6	6
Reach (mm)	625	886.5	786.5	1350	1250	967.5	1650
Payload (kg)	3	5	7	10	12	16	20
Weight (kg)	16.4	23.3	23.4	39.2	40.6	38.9	63.7
Mounting Surface Diameter (mm)	Ø140	Ø170	Ø170	Ø218	Ø218	Ø218	Ø260
Repeatability (mm)	±0.02	±0.02	±0.02	±0.03	±0.03	±0.03	±0.05
Linear Velocity (m/s)	≤2.5	≤3.4	≤3.0	≤4.0	≤3.8	≤3.0	≤2.6
Average Power (W)	150	200	200	500	500	600	1000
Peak Power (W)	1000	2000	2000	2000	2000	2000	3000
Installation Orientation	Any ceiling, Floor, Wall	Any ceiling, Floor, Wall	Any ceiling, Floor, Wall	Any ceiling, Floor, Wall	Any ceiling, Floor, Wall	Any ceiling, Floor, Wall	Any ceiling, Floor, Wall
IP Classification	IP54	IP54	IP54	IP54	IP54	IP54	IP54

Axis Movement	i3		i5		i7		i10		i12		i16		i20	
	Working Range (°)	Maximum Speed (°/s)	Working Range (°)	Maximum Speed (°/s)	Working Range (°)	Maximum Speed (°/s)	Working Range (°)	Maximum Speed (°/s)	Working Range (°)	Maximum Speed (°/s)	Working Range (°)	Maximum Speed (°/s)	Working Range (°)	Maximum Speed (°/s)
joint 1	±360	237	±360	223	±360	237	±360	178	±360	178	±360	178	±360	110
joint 2	±360	237	±360	237	±360	237	±360	178	±360	178	±360	178	±360	110
joint 3	±156	237	±162	237	±158	237	±167	223	±166	267	±161	267	±168	178
joint 4	±360	237	±360	237	±360	237	±360	237	±360	237	±360	237	±360	178
joint 5	±360	237	±360	237	±360	237	±360	237	±360	237	±360	237	±360	178
joint 6	±360	237	±360	237	±360	237	±360	237	±360	237	±360	237	±360	178

*各关节具备±360的能力,受限于应用场景,各关节可能达不到,请实际使用过程中注意。

*工作环境温度范围为0-50°C,工作环境湿度为90%相对湿度(非冷凝)。

Category	i-Series Control Box	C-Series Control Box	S-Series Control Box
Control Box Model	AUBO-CB-iS	AUBO-CB-C	AUBO-CB-S
Dimensions(mm)	400 * 320 * 160	340 * 100 * 260	175 * 132 * 44
Weight (kg)	12.5	7.5	约0.85
IP Classification	IP43	IP30	IP20
Power Supply	115/230VAC, 50/60Hz	100~240VAC, 50~60Hz(宽压)	DC48V
Cabling Connecting the Robot	5(可定制,最长8)	5	3
Cabling Connecting the Teach Pendant	4	-	-
Cabling Connecting the Power	5	5	-
Communication	Ethernet, ModBus-RTU/TCP, Profinet Ethernet/IP (选配)	Ethernet, ModBus-RTU/TCP, Profinet Ethernet/IP (选配)	Ethernet, ModBus-RTU/TCP, Profinet Ethernet/IP (选配)
Interface	SDK (C/C++/C#/Lua/Python/JavaScript Windows + Linux 系统)、支持 ROS/ROS2 系统、AP	SDK (C/C++/C#/Lua/Python/JavaScript Windows + Linux 系统)、支持 ROS/ROS2 系统、AP	SDK (C/C++/C#/Lua/Python/JavaScript Windows + Linux 系统)、支持 ROS/ROS2 系统、AP



Technical Specifications

Model(iS-Series Specification)	iS3	iS7	iS10	iS20	iS20L	iS25	iS35
Robot Arm Degrees of Freedom	6	6	6	6	6	6	6
Reach (mm)	625	886.5	1300	1647	2000	1700	2100
Payload (kg)	3	7	12	20	20	25	35
Weight (kg)	16	21.5	36	64	72	75.6	172
Mounting Surface Diameter (mm)	Ø140	Ø170	Ø218	Ø260	Ø282	Ø282	Ø423
Repeatability (mm)	±0.02	±0.02	±0.03	±0.05	±0.05	±0.05	±0.05
Linear Velocity (m/s)	≤2.5	≤3.6	≤4.0	≤3.5	≤3.5	≤3	≤4
Average Power (W)	150	200	500	1000	1000	1000	2000(预估)
Peak Power (W)	1000	2000	2000	3000	3000	3000	6000(预估)
Installation Orientation	Any ceiling, Floor, Wall	Any ceiling, Floor, Wall	Any ceiling, Floor, Wall	Any ceiling, Floor, Wall	Any ceiling, Floor, Wall	Any ceiling, Floor, Wall	Any ceiling, Floor, Wall
IP Classification	IP67	IP67	IP67	IP54 (可定制IP67)	IP54 (可定制IP67)	IP54 (可定制IP67)	IP54 (可定制IP67)

Axis Movement	Working Range (°)		Maximum Speed (°/s)		Working Range (°)		Maximum Speed (°/s)		Working Range (°)		Maximum Speed (°/s)		Working Range (°)		Maximum Speed (°/s)	
	Min	Max	Min	Max	Min	Max	Min	Max	Min	Max	Min	Max	Min	Max	Min	Max
joint 1	±360	237	±360	237	±360	178	±360	123	±360	104	±360	104	±360	104	±360	113
joint 2	±360	237	±360	237	±360	178	±360	123	±360	104	±360	104	±360	104	±360	113
joint 3	±156	237	±162	237	±167	237	±168	178	±360	178	±360	178	±360	178	±360	123
joint 4	±360	237	±360	296	±360	296	±360	296	±360	296	±360	296	±360	296	±360	237
joint 5	±360	237	±360	296	±360	296	±360	296	±360	296	±360	296	±360	296	±360	237
joint 6	±360	237	±360	296	±360	296	±360	296	±360	296	±360	296	±360	296	±360	237

*各关节具备±360的能力, 受限于应用场景, 各关节可能达不到, 请实际使用过程中注意。

*工作环境温度范围为0-50°C, 工作环境湿度为90%相对湿度(非冷凝)。

Control Box I/O/Tool I/O	Control Box (AUBO-CB-IS)		Tool End	手柄		Teach Pendant		
I/O Port	Digital In	16(general)/ 8 (safe)	4 (optional)	Model	AUBO SMARTSTICK		Model	AUBO-TP-IS
	Digital Out	16(general)/ 8 (safe)	4 (optional)	Dimensions	132mm*58mm*45mm (含急停开关厚度)		Dimensions	254mm*213.1mm*40.8mm
	Analog In	2	2	Weight	152g		Weight	1.0kg
	Analog Out	2	-	IP Classification	IP54		IP Classification	IP54
	RS485	2	1	Color	Black + Grey		Color	Orange + Black
I/O Power	Output Voltage	24V	0V/12V/24V					
	Output Current	3A max	2A (3A max)					



手柄



Teach Pendant

Technical Specifications

机械臂型号	S2	C3	C5
Degrees of Freedom	6	6	6
Reach (mm)	650	625	886.5
Payload (kg)	2	3	6
Weight (kg)	13.5	16	24
Mounting Surface Diameter (mm)	Ø140	Ø140	Ø170
Repeatability (mm)	±0.1	±0.05	±0.05
Linear Velocity (m/s)	2.0	≤1.9	≤2.8
Average Power (W)	150	150	200
Peak Power (W)	500	600	600
Installation Orientation	Any ceiling, Floor, Wall	Any ceiling, Floor, Wall	Any ceiling, Floor, Wall
IP Classification	IP54	IP54	IP54

Dimension Drawings

C3

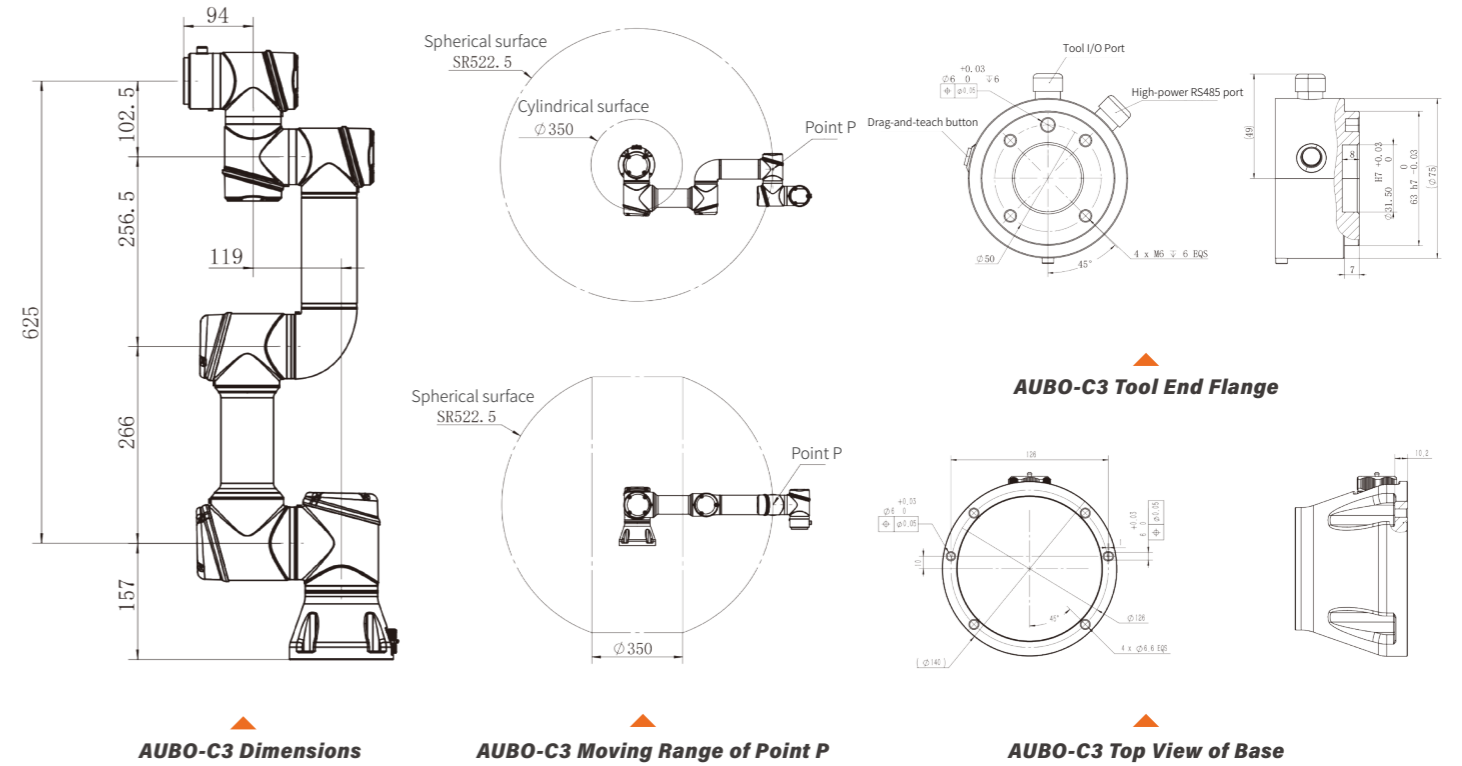

C5

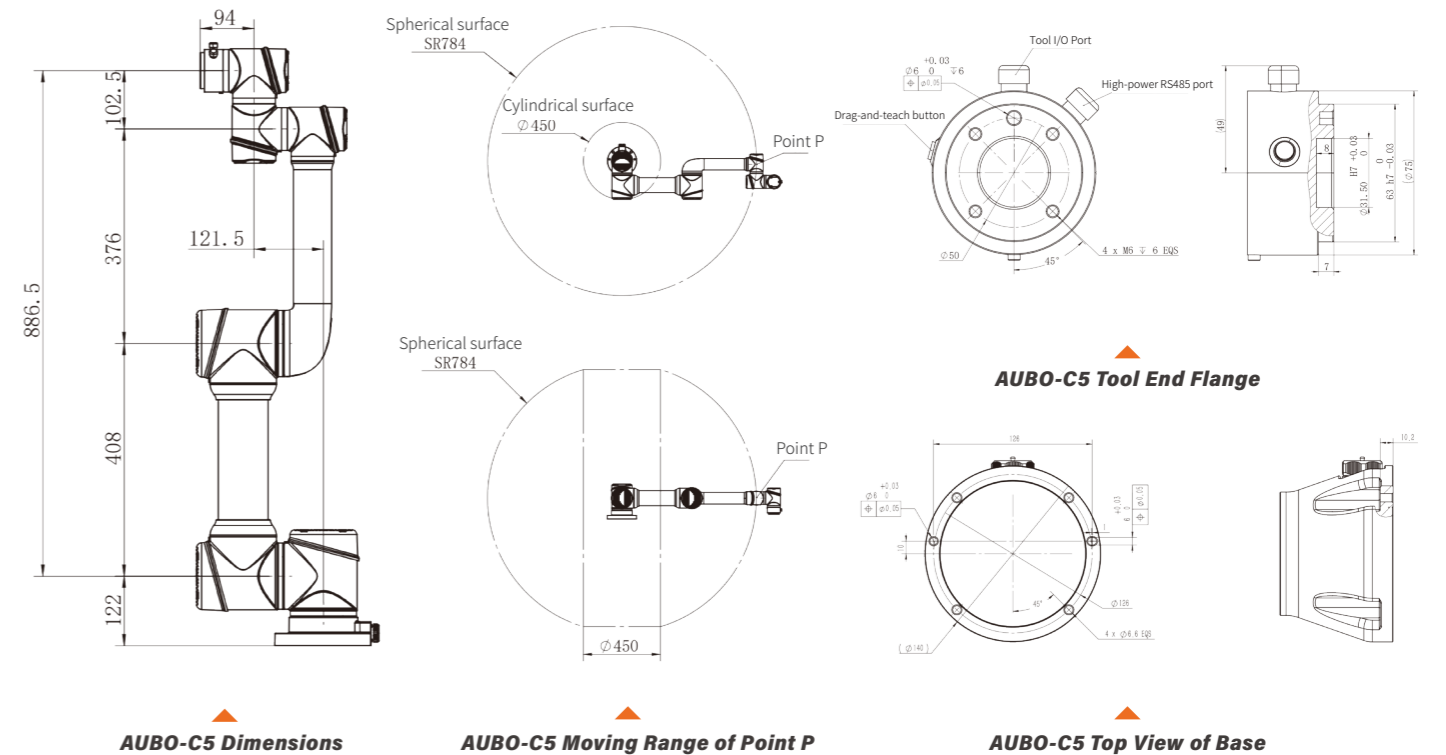

i3

Dimension Drawings

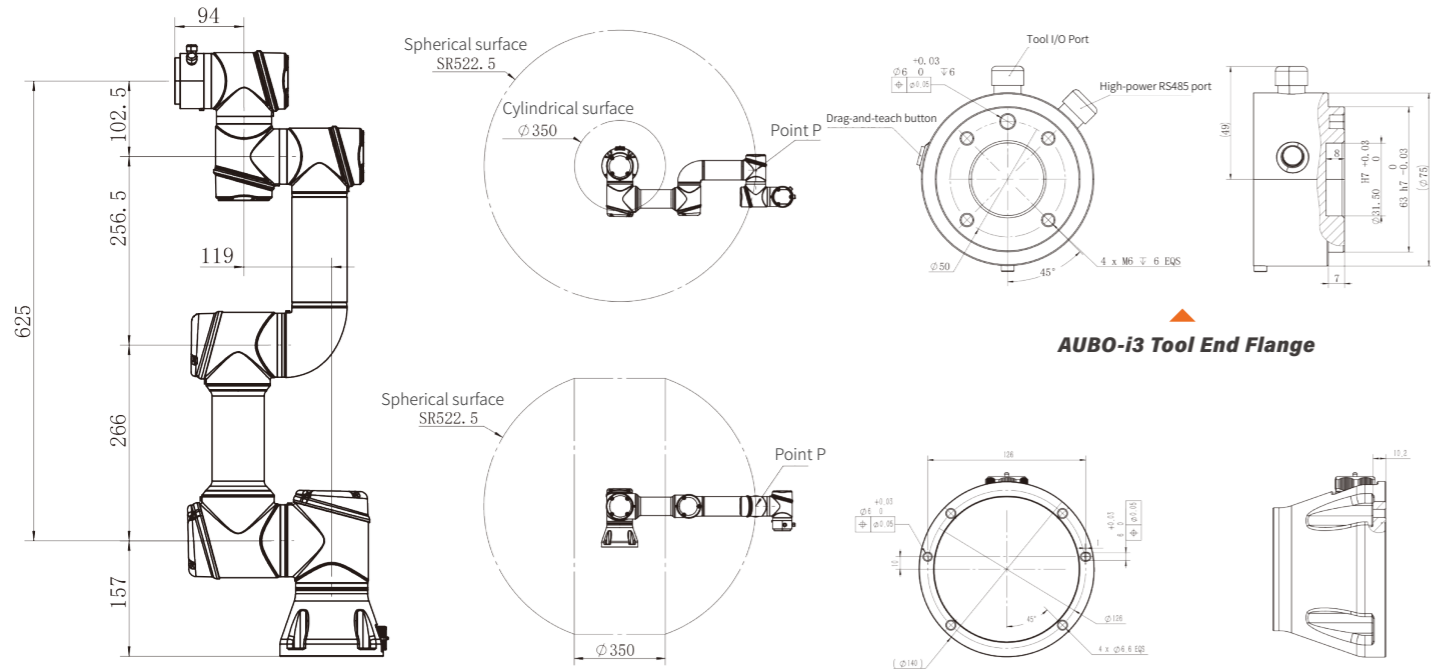

AUBO-i3 Dimensions

AUBO-i3 Moving Range of Point P

AUBO-i3 Top View of Base

Dimension Drawings

i7

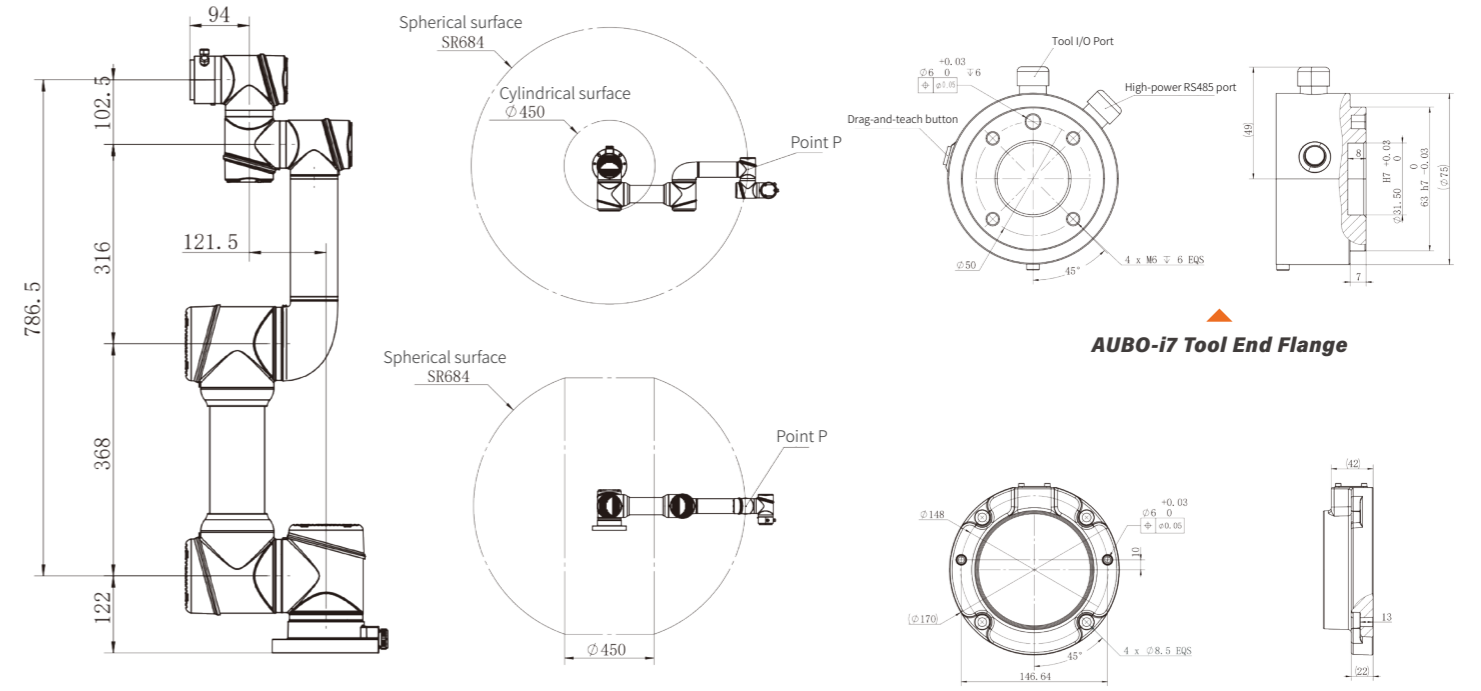

AUBO-i7 Dimensions

AUBO-i7 Moving Range of Point P

AUBO-i7 Top View of Base

i5

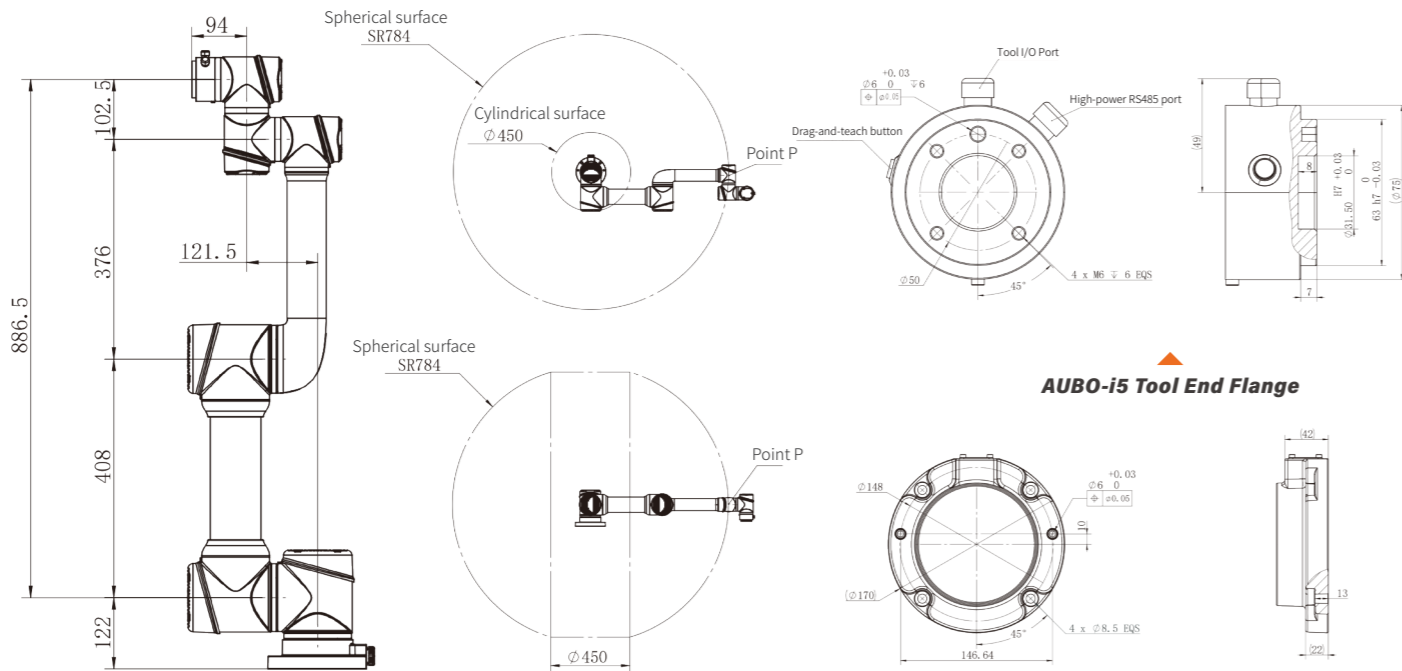

AUBO-i5 Dimensions

AUBO-i5 Moving Range of Point P

AUBO-i5 Top View of Base

i10

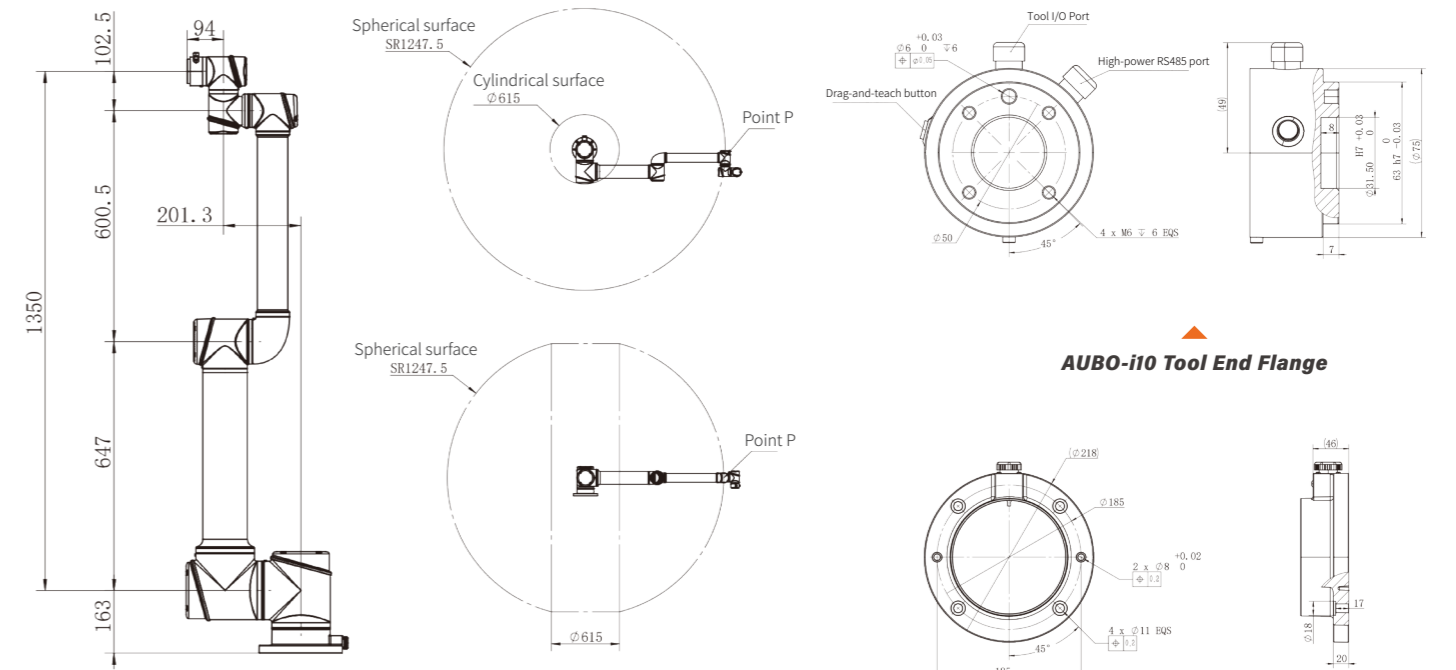

AUBO-i10 Dimensions

AUBO-i10 Moving Range of Point P

AUBO-i10 Top View of Base

iS3

Dimension Drawings

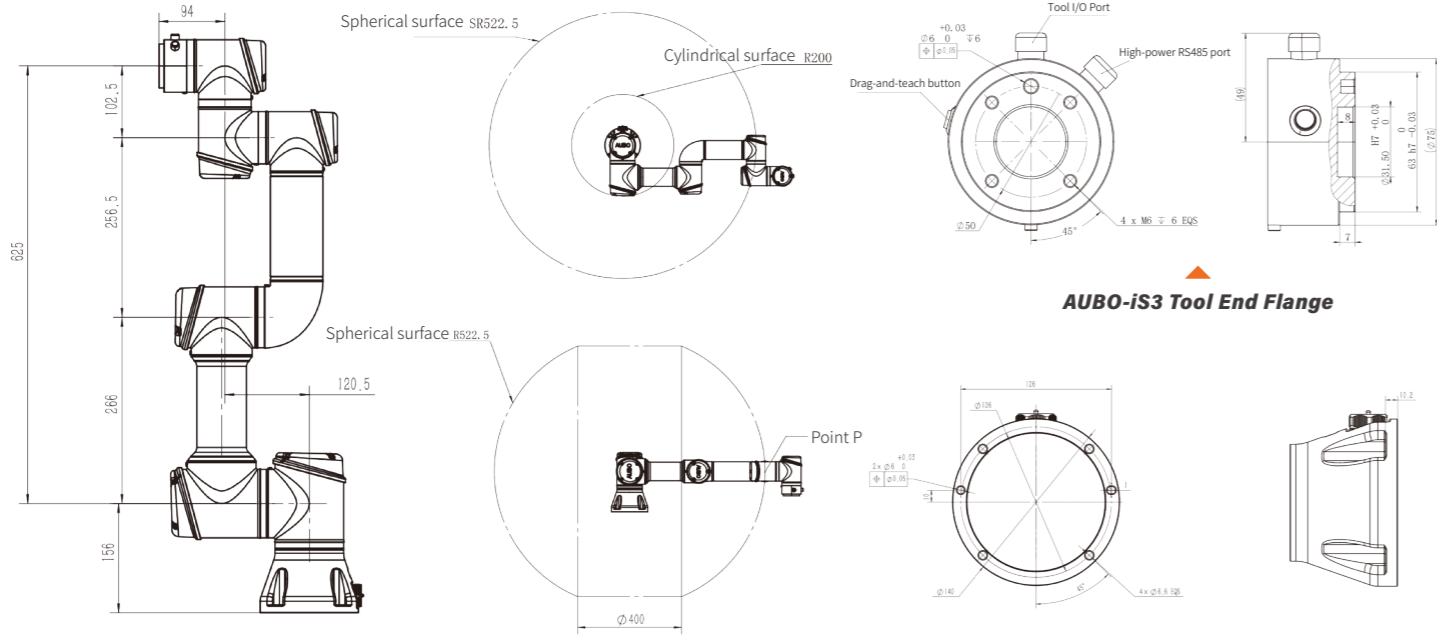

AUBO-iS3 Dimensions

AUBO-iS3 Moving Range of Point P

AUBO-iS3 Top View of Base

Dimension Drawings

iS10

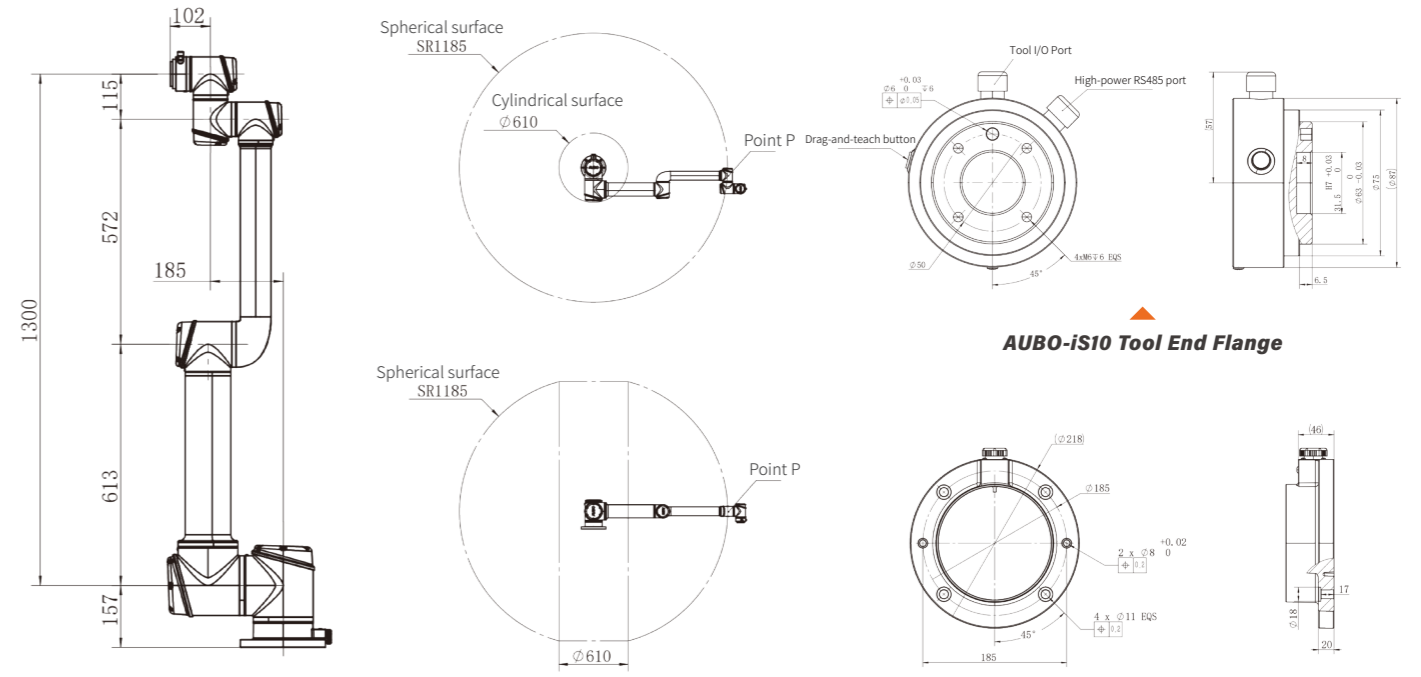

AUBO-iS10 Dimensions

AUBO-iS10 Moving Range of Point P

AUBO-iS10 Top View of Base

iS7

iS20

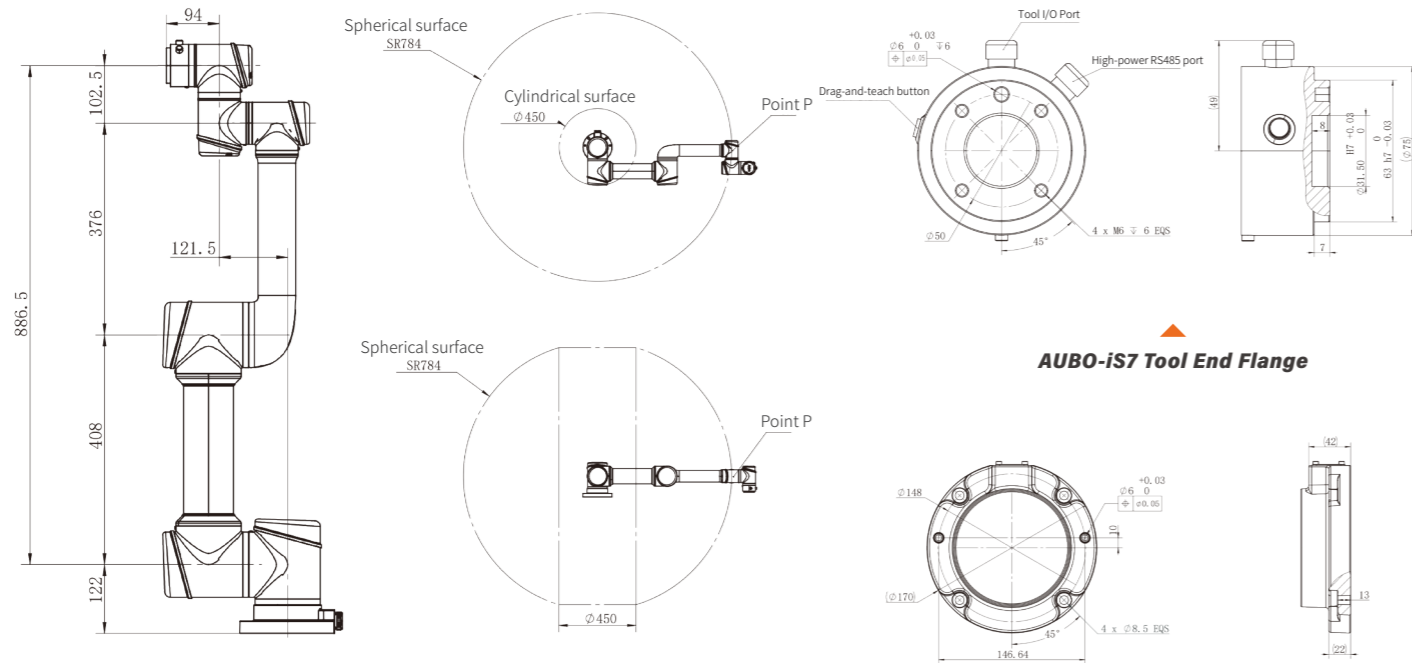

AUBO-iS7 Dimensions

AUBO-iS7 Moving Range of Point P

AUBO-iS7 Top View of Base

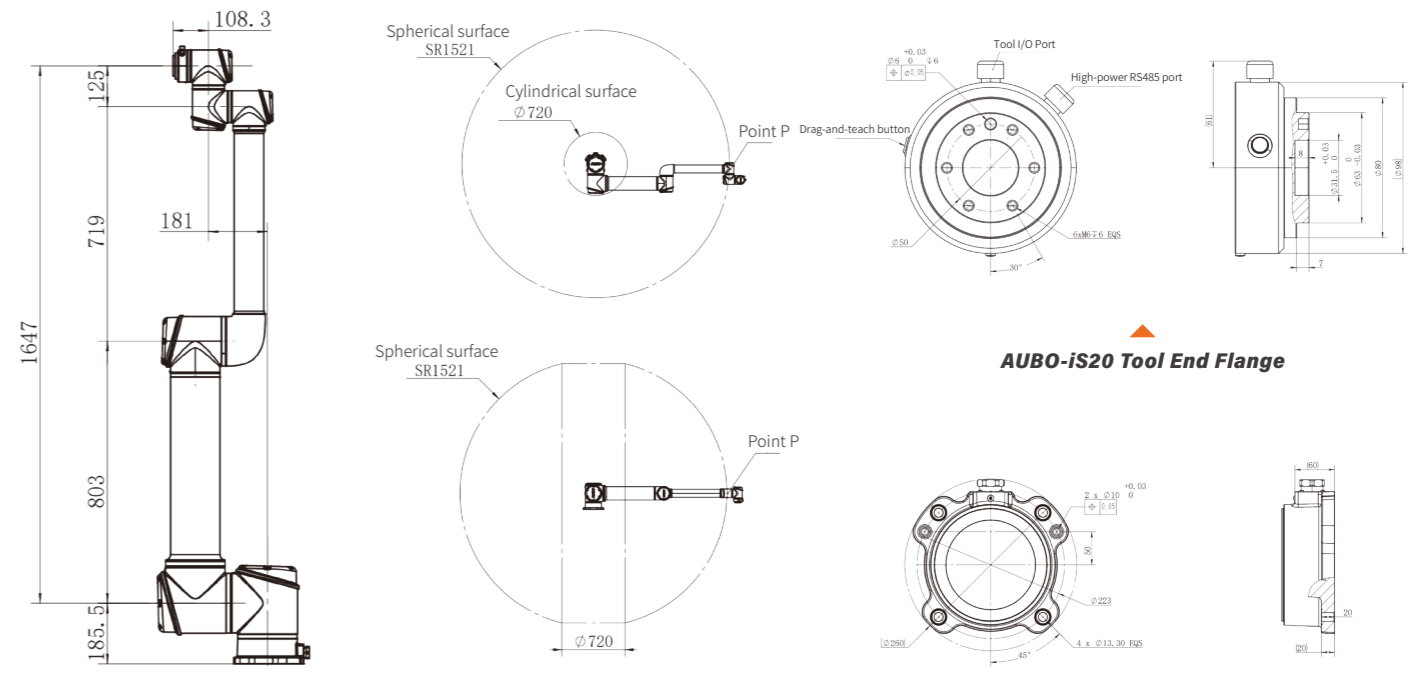

AUBO-iS20 Dimensions

AUBO-iS20 Moving Range of Point P

AUBO-iS20 Top View of Base

iS20L

Dimension Drawings

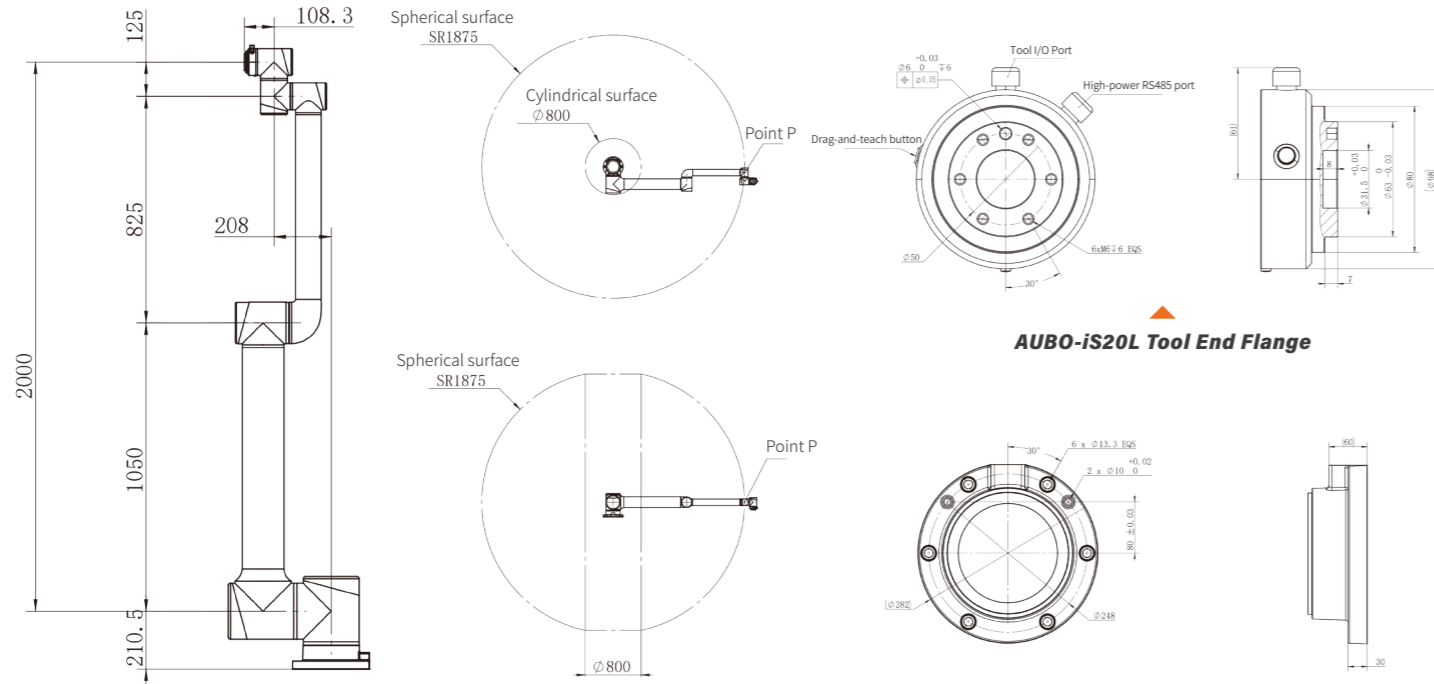

AUBO-iS20L Dimensions

AUBO-iS20L Moving Range of Point P

AUBO-iS20L Top View of Base

Dimension Drawings

iS35

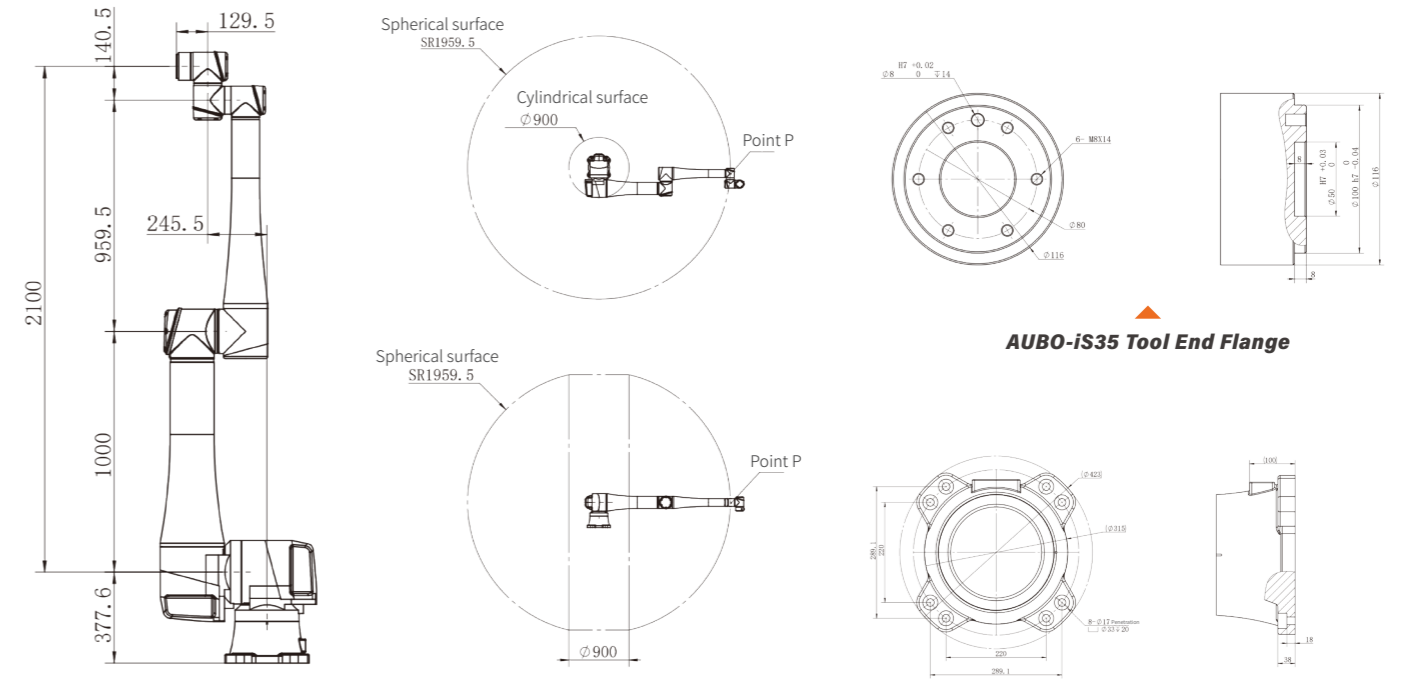

AUBO-iS35 Dimensions

AUBO-iS35 Moving Range of Point P

AUBO-iS35 Top View of Base

iS25

AUBO-AMR300S

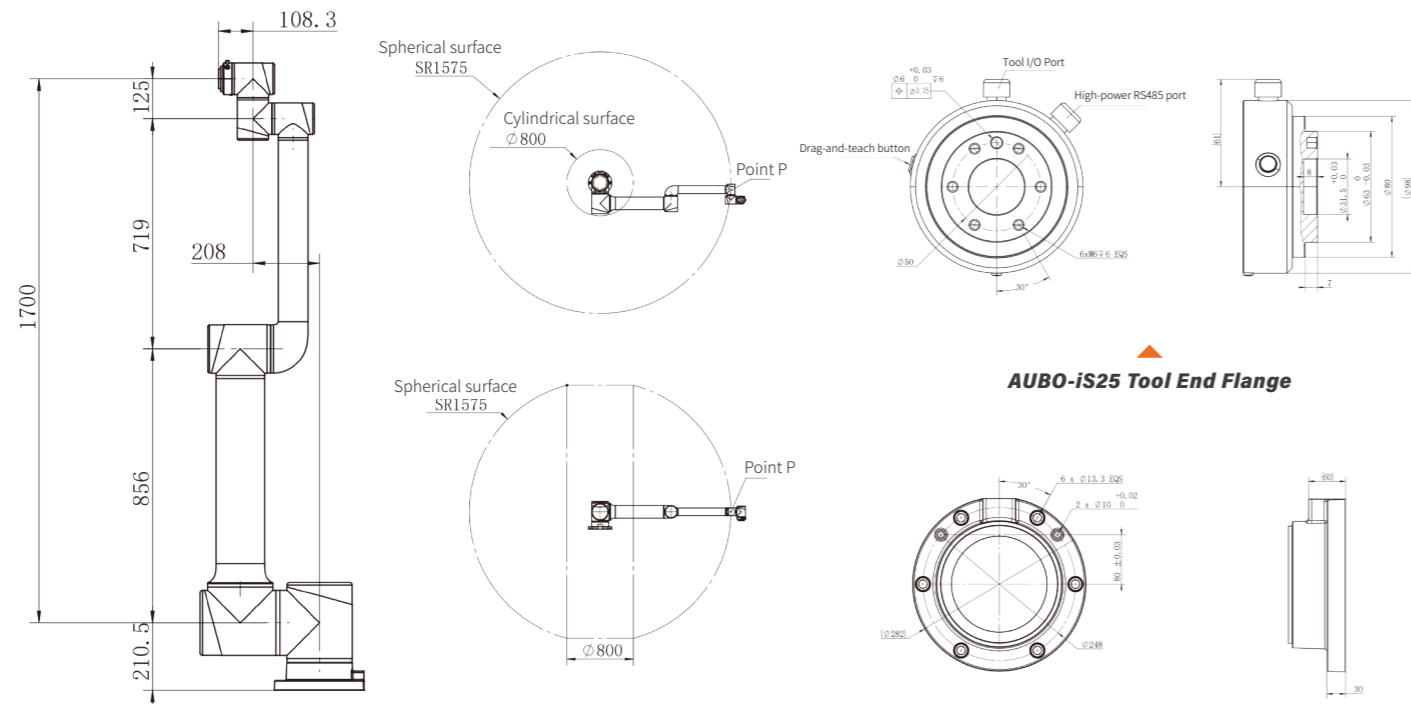

AUBO-iS25 Dimensions

AUBO-iS25 Moving Range of Point P

AUBO-iS25 Top View of Base

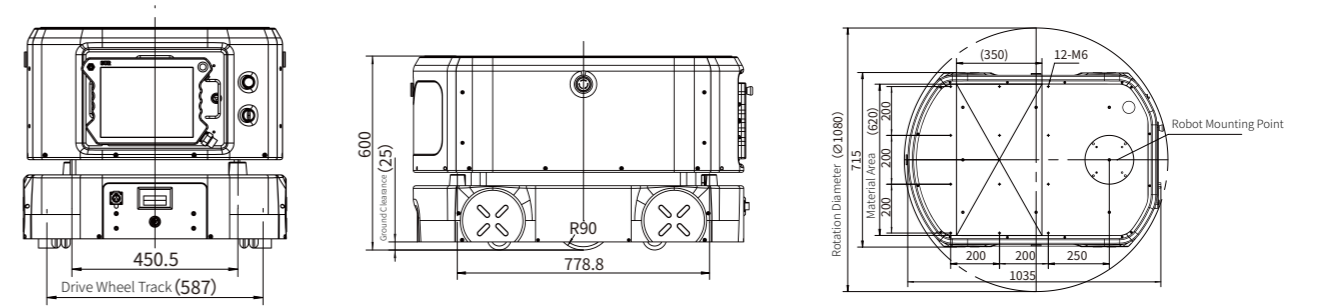

AUBO-AMR300S Rear View

AUBO-AMR300S Side View

AUBO-AMR300S Top View

Overall Dimension Drawing

AUBO